

CMT NEWS

I S S U E 1 6

Cabaret Mechanical Theatre

LOVE ISSUE

Meanwhile the campaign to make St Valentine's day a Public Holiday continues in that old unabated way. The powerful 'Hey! Don't express your emotions kid' lobby group have won the battle but you can help to win the war by buying some of our 'Hey! I think love is terribly important actually' mechanical toys. All seven (7) machines are handmade in small but unlimited editions and are for interpersonal adoration purposes only - no collecting please.

CAKE

Regular readers will know that my main purpose is to describe the objects and interpret their meaning in a way which makes them irresistible despite the scant information and simple illustrations. This task is not always easy. For instance, I

was just about to launch into a short piece about a dog who was torn in love, between a ballerina and a meringue (an understandable dilemma) when I happened to read that Pavlov, Ivan Petrovich (1849-1936) began his first independent research on heart physiology and the regulation of blood pressure in dogs. He developed the concept of the conditioned reflex and showed that gastric secretion in dogs could be stimulated by the sight of food and by nerve stimulation via the brain.

Therefore, for best effect, I suggest that you buy some food to stand by your **Pavlov's Jackal** or buy two Jackals and hope they feel for each other. Made by 14 Balls. A beating heart with wagging tongue and tail 4.5" tall and £60.50 (meringue not included).

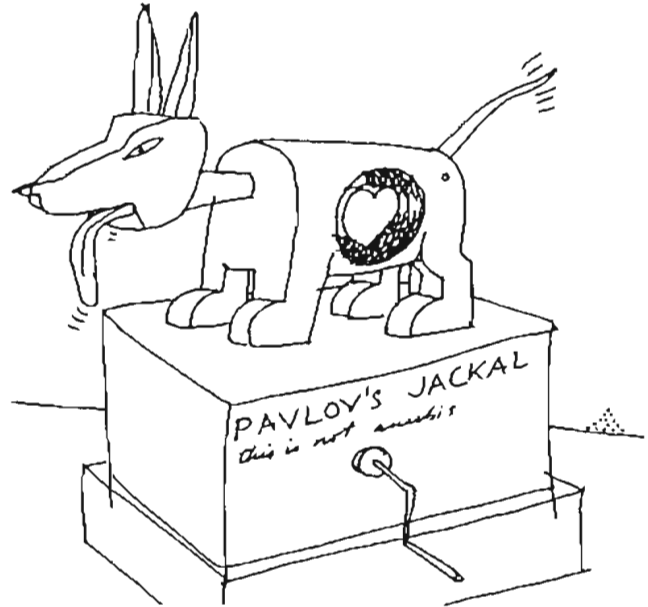

DOMESTIC

The second 14 Balls is called **Small Cheap Valentine**. It stands 2.5" tall and weighs almost nothing. The Anubis on a tightrope (in humiliating heart costume) derives its movement from a gentle tap. Alternatively, you could suggest your loved one secures it to their dashboard or washing machine. If they are lucky enough to own a car *and* a washing machine, you know what to do. Only £22.50.

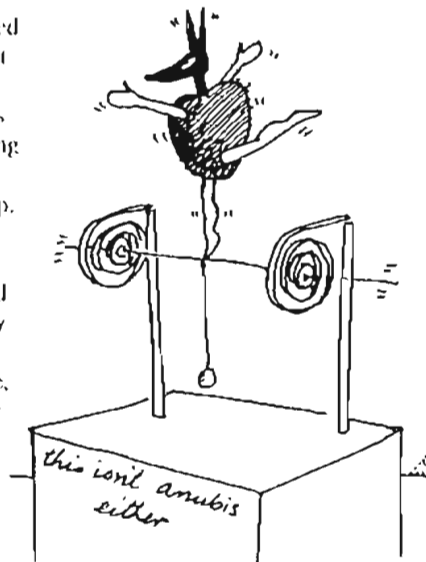

Valentines 1994

LIP READ

Well now, here's a rarity. A Sue Jackson design. In case you don't know I should tell you that not only is Ms Jackson paying me to produce this esteemed journal but she is also the founder and Great Goddess of CMT. Fortunately, the manufacture of **Put Your Heart Where Your Mouth Is** has been assigned to Sue Stolpe. Turn the handle to make the heart whole. For the inscription on the base it comes with two labels; the same as the title or, the simpler, I Love You. 8.5" tall at £29.50.

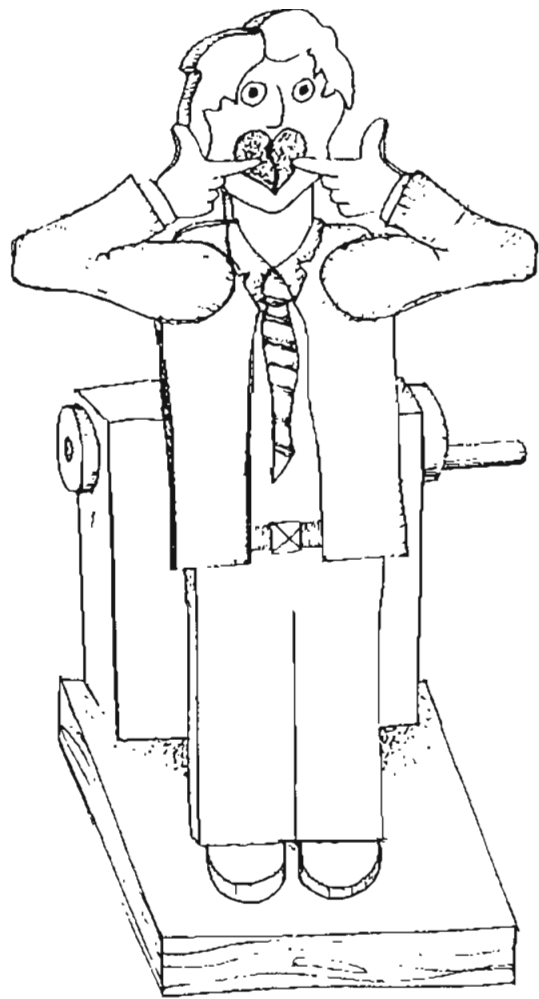

CAGED

Keith Newstead's offering is also made by Sue Stolpe and features a heart behind bars, struggling to escape. I know I'm not supposed to be selling Longman's Dictionary of 20th Century Biography but that Pavlov character got me thinking. It turns out that Christiaan Barnard kicked off his heart transplanting career with dog experiments! So do you think all the heart symbolism that's around during the Valentine period induces a subconscious shift to lower cholesterol foods? Anyway, **You've Captured My Heart** is nearly 7" high and £34.50.

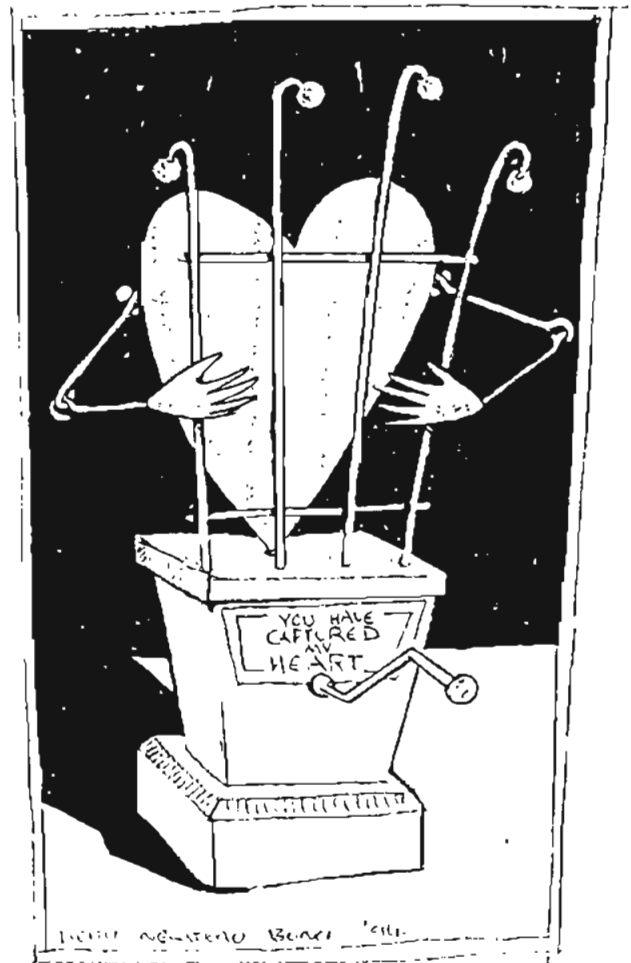

CMT NEWS 16

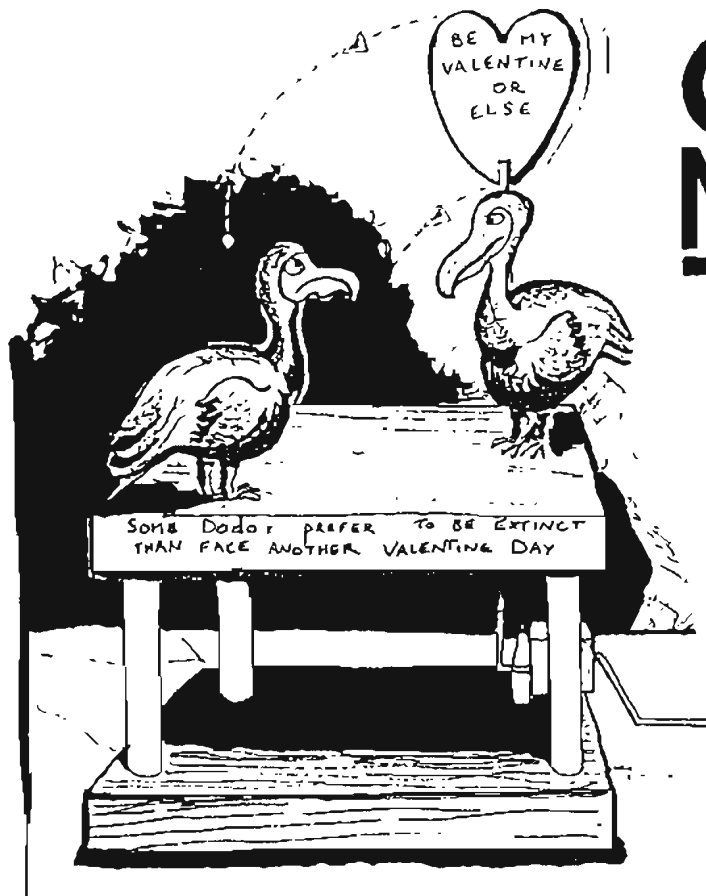

FLIGHT

Neil Hardy has chosen birds to carry the message of love. The first shows a pair of Dodos enduring their courtship ritual. One bird hits the other with a bright red sign but despite the subtlety of this approach, the second beast is unimpressed. **Valentine Dodos** 8" high, £28.20. The second depicts the famous **Valentine Peacock**. As legend would have it, this bird displays itself but once a year to its prospective mate. The legend doesn't say what happens if the bird is rejected. However, this machine will open its tail fans to reveal exotic plumage with a big red heart every time you turn its handle. 7" high and £34.50.

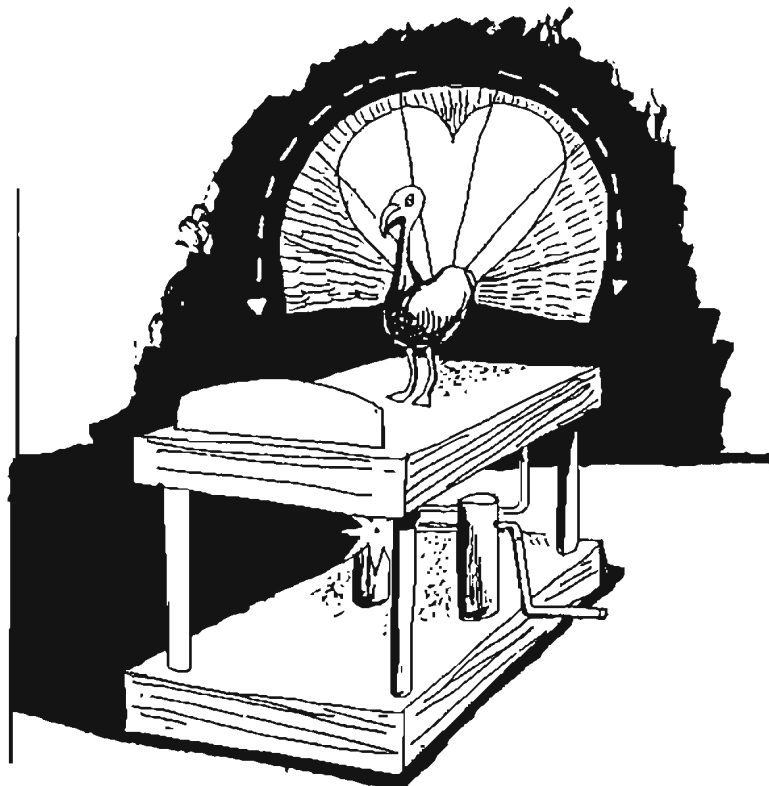

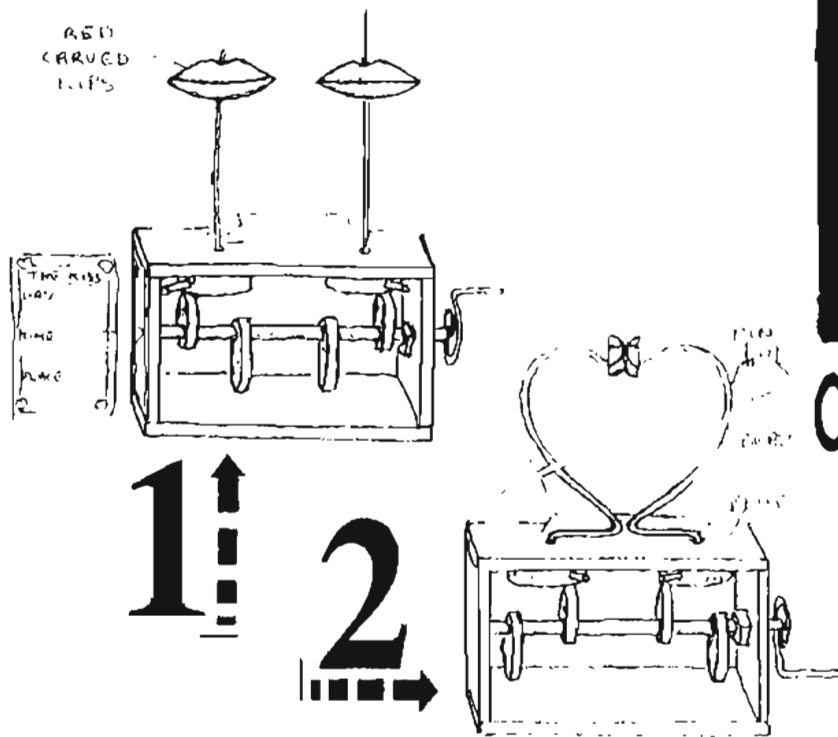

THE KISS

Finally, **the Kiss**. A pair of lips. Sorry, two pairs of lips, at first separate, come together; and by the magic of bent wire form a heart with an arrow. Designed and built by Sue Stolpe. 5" high. £23.50.

ORDERING

Please note that we will only charge credit cards when the goods are sent. Any orders which include unavailable items will be held until the complete order can be sent unless we are instructed otherwise. Phone for current information on availability.

Prices include VAT but not Post and Packing. If you cannot come in then phone or write to find out how much money (Sterling) we need. Easiest is to phone with a credit card to hand. We accept Visa, Access/Mastercard, Amex, Diners and JCB. Most orders sent overseas are exempt from VAT (17.5%). **Our phone number is (071) 379-7961. (International +44 71 379-7961). Credit card orders can be faxed anytime on (081) 693 7664 (Int. +44 81 693-7664) with card holder's signature and address, card number and expiry date.** Mail orders are handled by Marie. We are open from 10am (12 on Mondays) to 6.30 or 7pm every day. Our address is:

WHERE

Cabaret Mechanical Theatre
 33/34 THE MARKET COVENT GARDEN
 LONDON WC2E 8RE



This edition is dedicated to Louis Washkansky